

THIS DRAWING IS UNPUBLISHED. RELEASED FOR PUBLICATION ,19  
 © COPYRIGHT 19 BY AMP INCORPORATED, HARRISBURG, PA. ALL INTERNATIONAL RIGHTS RESERVED. AMP PRODUCTS MAY BE COVERED BY U.S. AND FOREIGN PATENTS AND/OR PATENTS PENDING.

LOC	DIST	P	F	REVISIONS			DATE	APPROVED
AF	50			ZONE	LTR	DESCRIPTION		
					L	REACTIVATE -2 AF-5693	11/9/85	VP/msf

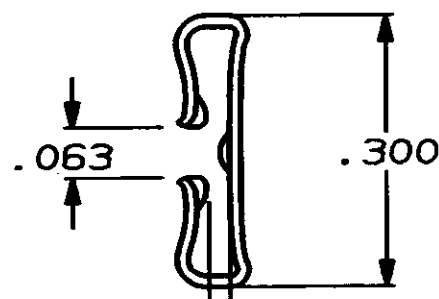
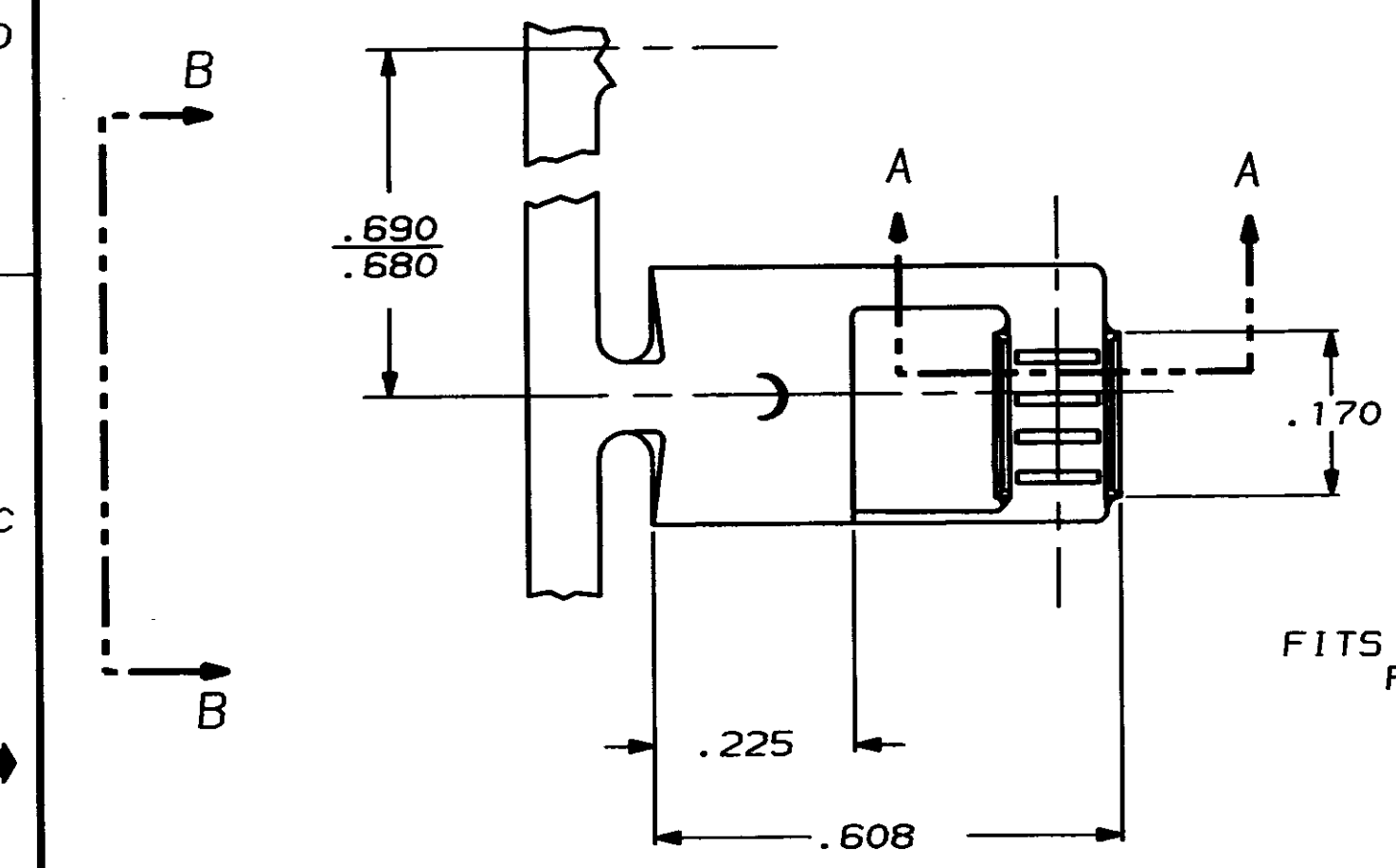

FITS .250 SERIES FASTON TAB

VIEW B-B

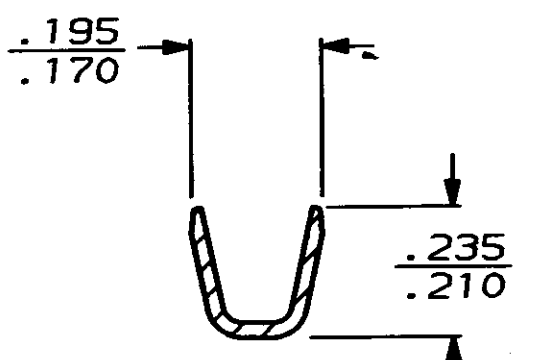

SECTION A-A

1 - CONTINUOUS STRIP ON REELS.

2 #14 STRANDED OR SOLID	.032	TIN	.018 BRASS	60960-3
2 #12 STRANDED ONLY	.032	---	.018 BRASS	60960-2
12-10 STRANDED OR SOLID	.032	NICKEL	.018 STEEL	60960-1
WIRE SIZE	TAB THK ± .001	FINISH	MATERIAL	PART NO

.220	F	.140	101	2 #14
			123	2 #12
			.111	10
			.093	12
STRIP LENGTH ±.015	TYPE	WIDTH	±.002 HEIGHT	WIRE
WIRE BARREL CRIMP				

UNLESS OTHERWISE SPECIFIED DIMENSIONS ARE IN INCHES TOLERANCES ON: 2 PL DEC ± 3 PL DEC ± .015 ANGLES ±	DR JR RUTH 10-9-85
	CHK G YETTER 10-18-85
	APPD C MEYERS 10-21-85
	APPD R KUZO 10-28-85
MATERIAL	PRODUCT SPEC
FINISH	APPLICATION SPEC 114-2079
	WEIGHT

AMP INCORPORATED Harrisburg, Pa. 17105		
NAME .250 SERIES FLAG FASTON RECEPTACLE		
SIZE B	FSCN NO 00779	DRAWING NO 60960
SCALE NTS	SHEET 1 OF 1	